

Testing:

Once connected to the 240V mains supply, the unit must be allowed to charge the battery for at least 24 hours. Conduct the following tests:

- For the first test, the emergency lamp must remain illuminated for at least 2 hours after disconnection from the mains supply.
- Subsequent tests require the unit to illuminate for at least 90 minutes. The results of all tests are required to be recorded in a service logbook, which is to be kept on-site at all times. If the unit fails to remain illuminated for the requisite time, remedial action must be taken to repair the situation and once completed, the unit must pass a subsequent test. For more specific information, please refer to the current edition of the AS 2293.3 Standard.

Trouble Shooting:

Below are a list of common problems and their possible causes.

Fault: The Green LED Test Switch indicator is not illuminated.

Check: A.C. is connected and is turned on.
Battery is connected
Test Switch for damage.

Fault: Lamp does not illuminate in emergency mode.

Check: A.C. is connected.
Lamp is correctly inserted.
Battery is connected

Fault: Lamp illuminates in emergency mode, but only stays on for a short period.

Check: Battery has been allowed to charge for at least 24 hours.
Battery for damage.

Fault: Green LED flashes once every 5 seconds-Battery is disconnected

Check: Battery is connected.

Fault: Green LED blinks off once every 5 seconds- Charging very flat battery

Allow 20min to recover battery then recheck

Fault: Green LED flashes at 2Hz (Fast flash)- Faulty battery

Replace battery

Changing Exit Legend Inserts:

The Exit comes with an assortment of standard legends.

1. To remove the legend, grasp the centre of the bottom trim piece and pull down slightly to expose the legend edge. See photo.
2. Grasp the bottom edge of the legend and slide the existing legend out of the blade, while working the edges out along the sides.
3. Slide the new legend into the blade, ensuring to fit the edges into the sides then slide the legend to the top of the blade. Insert one bottom corner then the other. Slide the legend down into the bottom trim.

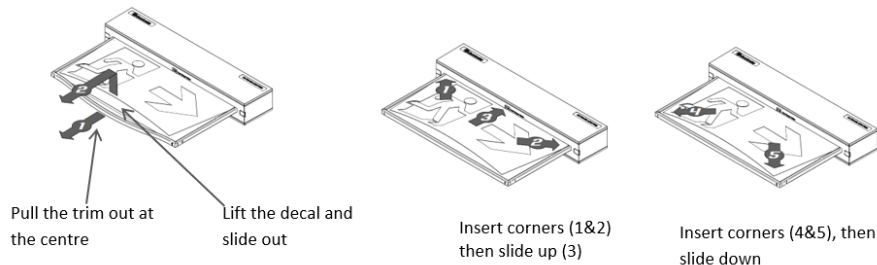

Glider Surface Mount Exit

Installation & Maintenance Instruction Leaflet



Victoria (Head Office & Manufacturing)

Website: www.clevertronics.com.au

Email: info@clevertronics.com.au

Phone: +61 3 9559 2700

New South Wales

Phone: +61 2 8805 6400

Queensland

Phone: +61 7 3442 9700

South Australia/Northern Territory

Phone: +61 8 8301 8800

Western Australia

Phone: +61 8 9207 0000

New Zealand

Phone: +64 800 548 448

Designed in Australia to comply with the requirements of AS2293.3: 2018, AS CISPR15: 2017

Models:

GLIDER-SM-xx

Options:

Black

xx = BLK

Spare Parts:

1560180

Replacement Battery

8012080

Replacement Emergency LED Board

8003553

Replacement Emergency Driver

Important:

It is illegal for anyone, except for a licensed electrician to install or maintain this product. Before installation, ensure that the electricity supply has been switched off and isolated. Installation must be carried out in accordance with the relevant Australian and International Standards.

Maintained/Non-Maintained Operating Mode:

Press the Test Button 5 times within a 4 second period to toggle operation of the fitting between Maintained and Non-Maintained mode

This luminaire (with reinforced insulation between control/LED terminal and AC Supply) contains non-user replaceable light source – to be replaced (if required) by the manufacturer or their service agent or a similar qualified person.

Installation:

The GLIDER-SM LED Exit is a surface mount fitting. It can be attached directly to any solid surface. Please follow the steps below to install the GLIDER-SM Exit:

- Open the fitting by disengaging the 2 clips on either side of the blade.
- Locate the mounting surface.
- Drill holes in the mounting base to suit the mounting method, Ceiling or Wall (see images).
- Use the mounting bracket to mark-out the mounting holes for Ceiling or Wall Mount.
- Drill power access hole as required.
- Mount the fitting using appropriate fixings.
- Route the power to the mains connection and connect the 240VAC supply.
- Connect the Battery
- Attach the blade assembly to the bracket make sure that both Clips are completely engaged.
- Apply power to the fitting and test.
- This luminaire contains non-user replaceable light source and battery.

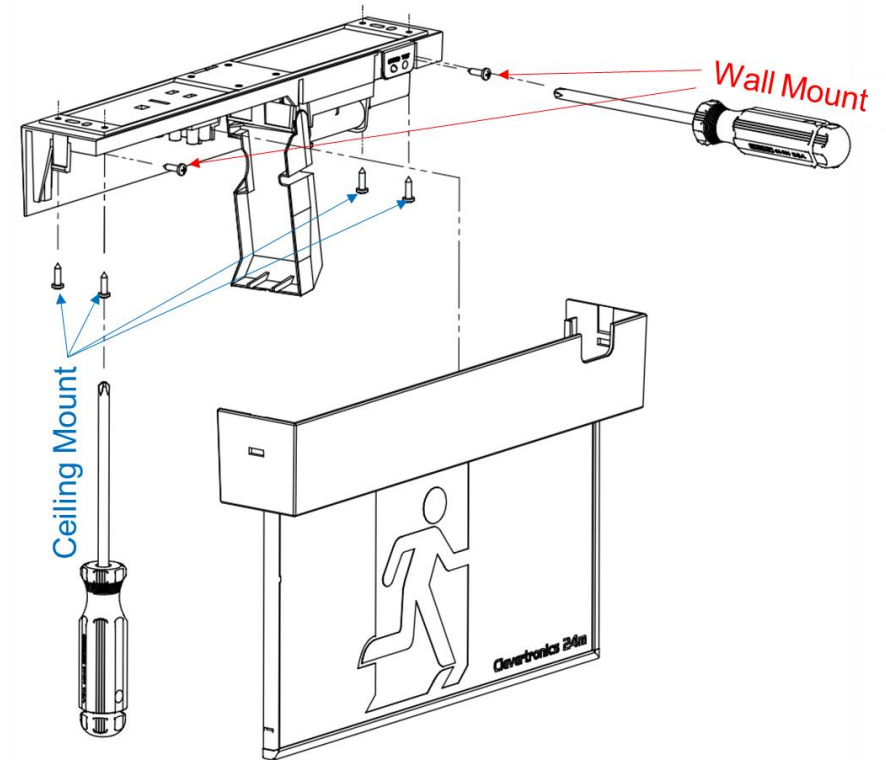
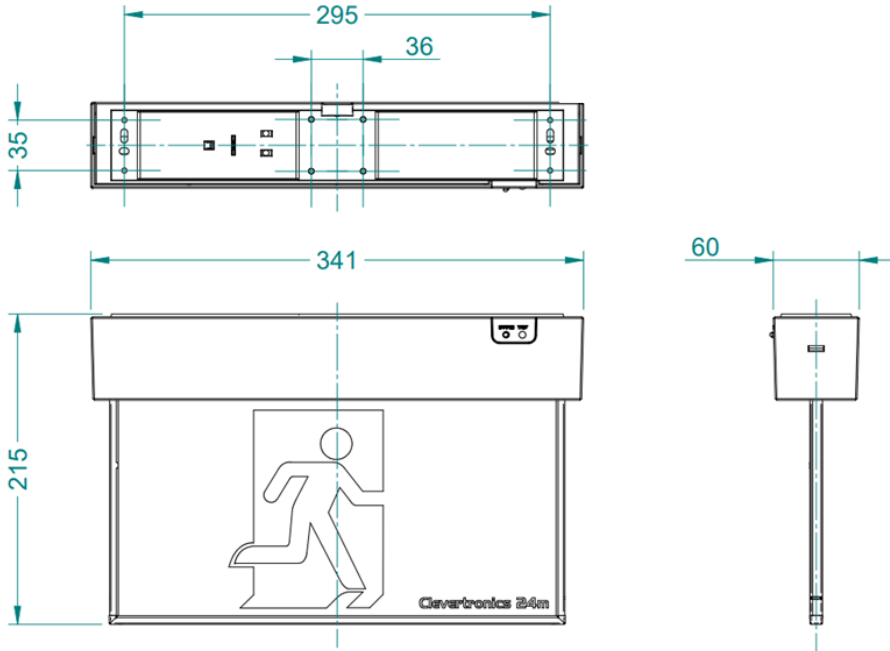

Battery Replacement:

- Use only the battery recommended on the label inside the Exit and on this instruction.
- Remove the exit of the bracket by disengaging the Locking clip
- The battery is located in the top of the fitting.
- Unplug the battery from the PCA and remove it.
- Insert the new battery into the holder, route the DC cable to the PCA and plug the new battery into the connector.
- Reinstall the Exit back to the bracket making sure that both Clips are completely engaged.

Caution:

On many building sites, power circuits may be cut off in an uncontrolled and repetitive basis during construction. As a result, any Exit & Emergency Units, on these circuits, will have their batteries discharged or "cycled". The battery in this fitting has been selected to give excellent long-life performance in a controlled AS2293 testing environment. Excessive battery cycling will reduce through-life performance and may lead to premature battery failure. Battery warranty claims, as a result of such abuse, are specifically EXCLUDED from Clevertronics warranty terms.

Warranty:

For Product Warranty information and Terms and Conditions of Sales please refer to our website <http://clevertronics.com.au/terms-conditions-sale-australia-nz/>